

# **Host Compatibility Measurements for the Extended Hybrid Mode of IBOC Digital Audio Broadcasting**

**Prepared for the Federal Communications Commission  
October 29, 2004**

**by  
John Kean, Senior Technologist  
National Public Radio  
Washington, DC 20001  
(202) 513-2476  
[jkean@npr.org](mailto:jkean@npr.org)**

# 1 Introduction

This study is intended to determine the effect of adding the Extended Hybrid Mode to IBOC DAB Primary Mode transmission on stereo and SCA reception of the Analog Host. This study was motivated by National Public Radio’s desire to expand the capabilities of IBOC DAB transmission to support audio information services and other data streams for the public.<sup>1</sup> Since Extended Hybrid Mode transmission adds additional OFDM carriers to the Primary Mode digital spectrum, NPR sought to test this mode’s effect on consumer stereo receivers as well as FM SCA subcarrier radios. This test procedure is commonly referred to as Analog Host Compatibility measurement of IBOC DAB.

source: iBiquity Digital Corp

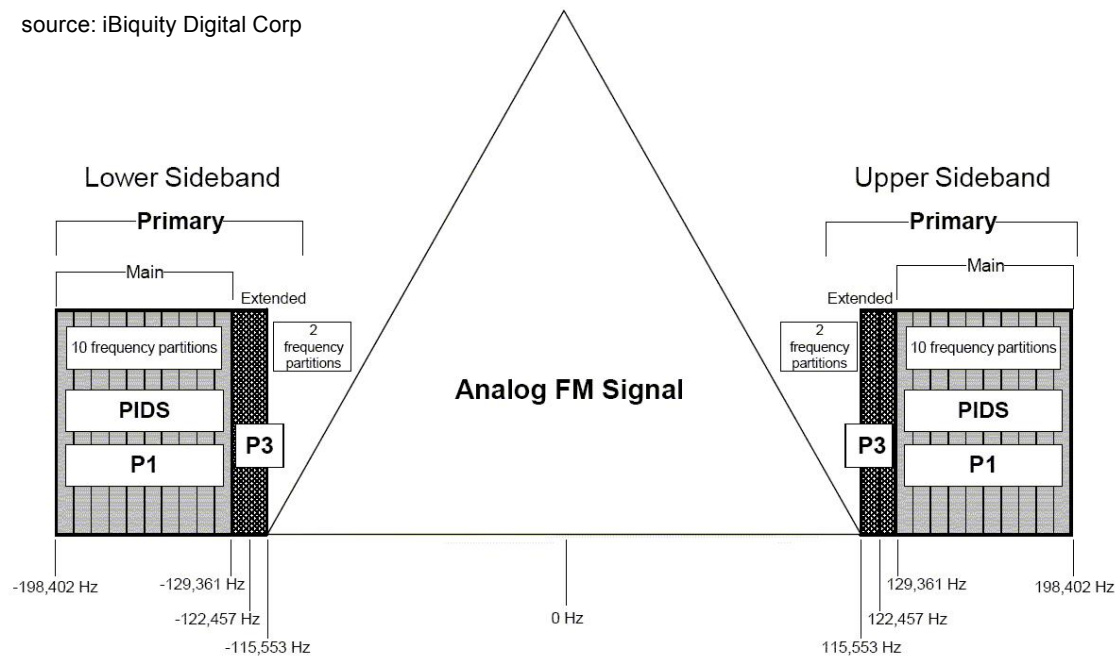

**Figure 1 - RF channel spectral mapping for Primary Main and Extended Hybrid Modes**

For hybrid analog/digital broadcasting, the iBiquity HD Radio™ system<sup>2</sup> adds a number of OFDM carriers above and below the Analog Host FM Signal as shown in Figure 1. Groups of carriers are formed into frequency partitions approximately 6904 Hz each in width. Ten of the outer partitions form the Main group, providing a 96 kbps digital stream for the primary audio channel (and optionally, supplementary audio channel). Additional sets of partitions are allocated symmetrically within the pair of Main partitions, termed the Extended Hybrid Mode. These interior partitions provide ancillary data streams at approximately 12.5 kbps each, and may be operated as an individual pair (MP2 mode), as two partition pairs (MP3 mode) or four partition pairs (MP4 mode). The figure illustrates two partition pairs for Mode P3 or “MP3”.

<sup>1</sup> This study was supported with funds provided by the Corporation for Public Broadcasting. NPR proposed to CPB a particular interest in the effect of IBOC Extended Hybrid Mode on FM SCA subcarriers. Many NPR member stations transmit SCA subcarriers providing audio information services to the visually impaired.

<sup>2</sup> In-Band On-Channel Digital Audio Broadcasting is authorized by the FCC with the iBiquity Digital Corp. system, as detailed in Appendix B of the First Report & Order, MM Docket 99.325

The emission generated by the Primary Main OFDM carriers is defined to be 1/100<sup>th</sup> of the power of the analog Host carrier, or -20dBc. There are a total of 382 carriers in the Primary Main upper (356 to 546) and Primary Main lower (-356 to -546) groups. The two partitions of Extended Hybrid mode MP3 occupy 76 carriers for upper (318 to 355) and lower (-318 to -355) groups. Additional power contributed by the MP3 carriers is proportional to the number of carriers as determined below:

$$10 \times \log\left(\frac{76}{382}\right) = 0.8dB .$$

Thus, the MP3 mode of Extended Hybrid operation adds 0.8dB to the overall IBOC emission, increasing the power to -19.2 dBc, relative to the analog Host carrier. Since Extended Hybrid carriers are located closer in frequency to the Analog Host than the Main partitions, it is appropriate to consider what effect this additional energy will have on analog stereo and SCA subcarrier operation. The following section discussed the methodology used to collect Host compatibility data.

## 2 Test Methodology

An instrumentation Test Bed was constructed to generate the MP1 and MP3 test signals, as shown in Figure 2. Two Harris Dexstar® IBOC-DAB exciter were employed to produce the digital RF signals. The exciter were alternately muted from their front panel controls to allow measurement with either MP1 or MP3. Each exciter contains automatic power control, which maintains the output at 2.0 mW, however, this does not provide the 0.8 dB increase required for MP3. To balance the proper RF ratios the exciter were connected to a passive combiner after adding a 0.8 dB attenuator to the MP1 exciter. Two 10 dB attenuators were added to provide an approximate 100:1 power ratio with the Host FM generator. Exact level trim was performed at the FM generator using a HP 4378 power meter to accurately measure the digital and analog signals.

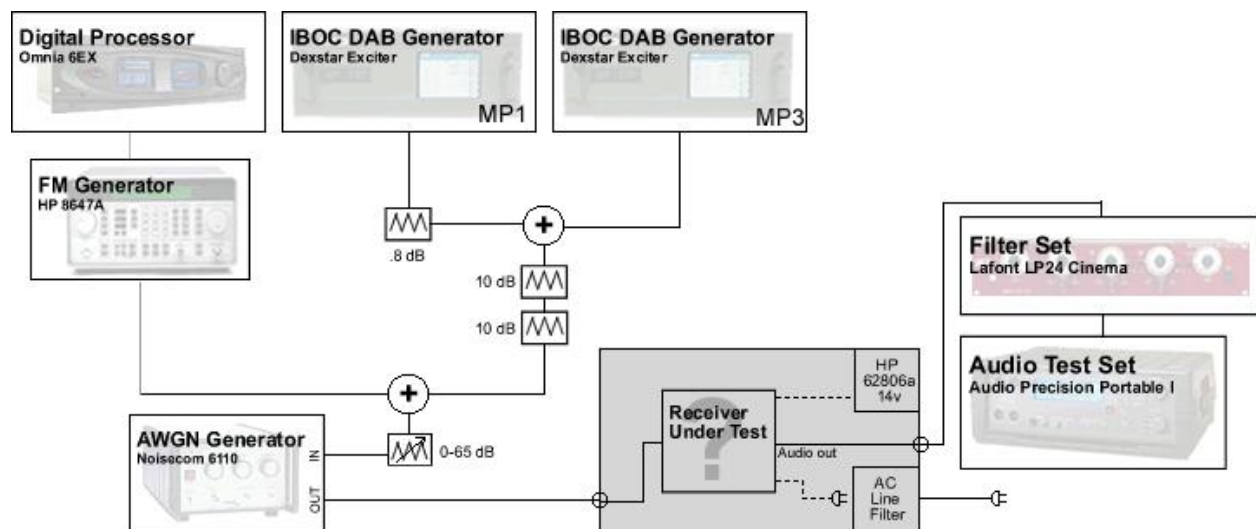

Figure 2 – Test Bed for hybrid Analog/Digital testing.

The Host FM generator was connected to an Omnia 6EX-HD+FM digital audio processor, which generates the 19 kHz Stereo Pilot. To provide the audio SNR reference for each receiver, a 400 Hz tone was fed to the left and right channels at 100% composite modulation (including Pilot). During SNR measurement, the calibration tone was turned off and only the Pilot modulated the analog Host.

Previous studies of Host compatibility performed by iBiquity for the National Radio System Committee included the addition of white Gaussian noise, which were intended to represent levels of analog co-channel interference.<sup>3</sup> A NoiseCom 6110 was the Additive White Gaussian Noise (AWGN) generator. A 0-65 dB attenuator was placed ahead of the noise generator, which contained an internal noise attenuator and signal combiner, so that noise levels could be established independently from the hybrid analog Host and IBOC signals.

Double-shielded coaxial cables were used to interconnect the equipment and a shielded test box containing a test receiver. This ensured that ingress from off-air FM signals would not affect the receiver measurements. All measurements were performed at 98.1 MHz, except the SCA receivers, which were fixed-tuned to 91.3 MHz (Compol), 90.9 MHz (McMartin) and 89.5 MHz (Norver).

Audio SNR measurements were performed with an Audio Precision Portable 1 test set using unweighted RMS measurement. To avoid stereo Pilot leakage in the measurements, a Lafont Audio Labs Cinema Filter Set was connected ahead of the AP Portable 1 and tuned for a deep 19 kHz notch. In cases where internal AC hum was evident, the filter set was set to 120 Hz high-pass to minimize this influence. A 15 kHz low-pass filter was used with a few of the inexpensive radios exhibiting supersonic noise, as noted in Appendix 1.

Equivalent signal strengths were determined by subtracting all system losses for the signal path from the signal power of the FM generator. (As noted earlier, the FM generator power output was preset to the appropriate ratio with the respective IBOC exciter signals.) The FM Host signal strength in mV/m was calculated by the following equation:

$$E_{equiv} = 60 + 20 \log \sqrt{\frac{480\pi^2 p_o}{\lambda^2 \times 1000}}$$

where  $p_o$  is the signal power in watts and  $\lambda$  is the wavelength in meters (3.06m at 98.1 MHz).

All of the receivers except two pocketsize portables had antenna terminals or an external antenna for connection to the Test Bed. As noted in Appendix 1, these receivers were capacitively coupled to the signal output though a few inches of center conductor wire laid along the audio cable connected to the unit's headphone jack. The actual level of signal coupled into these units cannot be determined. None of the receivers provided an input impedance rating, and since the Test Bed operated with a fixed 50-ohm output impedance, some mismatches in signal power are

---

<sup>3</sup> The NRSC Noise Report, November 2001, referred to two consulting reports as well as its own field-testing, which indicated that co-channel FM interference in the San Francisco market was at least 15 dB $\mu$ . This field strength may be represented in a test bed by a Gaussian noise level of approximately 30,000 degrees Kelvin ( $^{\circ}$ K). The report noted that field measurements in the Baltimore observed a noise level of approximately 200,000 $^{\circ}$ K. To consider highly frequency-congested areas of the US, this Host compatibility study included a test at 300,000 $^{\circ}$ K or 26.2 dB $\mu$ .

expected. However, testing of all the receivers indicated that the signal strength was not critical to measured changes in noise between MP1 and MP3. Therefore, the mismatches are considered a minor error in the results.

Testing revealed that IBOC noise began to rise in some receivers at an FM signal input in the vicinity of 90 dB $\mu$ . To determine if the noise contributions of IBOC DAB to Host stereo or SCA were affected by signal level, receivers were tested at three signal levels, equivalent to the FCC field strengths of 60 dB $\mu$ , 90 dB $\mu$  and 100 dB $\mu$ .

The actual audio SNR for the receiver testing is contained in Appendix 1 for the listed receivers: Table 5 – Automobile, Table 6 - Component Receivers & Tuners, Table 7 – Compact & Portable Radios, and, Table 8 – FM SCA Subcarrier Receivers. To simplify the results, increases (in dB) from MP1 to MP3 mode are summarized below for three equivalent signal strengths, with no added white Gaussian noise, with 30,000°K noise and with 300,000°K noise:

**Table 1 – Audio SNR change from MP1 to MP3 for all automobile radios.**

<b>AWGN (°K)</b>	None	30,000	300,000
60 dB $\mu$	0.1	0.0	0.0
90 dB $\mu$	0.0	0.1	0.0
100 dB $\mu$	0.1	0.0	0.0

**Table 2 – Audio SNR change from MP1 to MP3 for all component receivers and tuners.**

<b>AWGN (°K)</b>	None	30,000	300,000
60 dB $\mu$	0.3	-0.1	0.0
90 dB $\mu$	0.8	0.8	0.8
100 dB $\mu$	1.3	1.3	1.3

**Table 3 – Audio SNR change from MP1 to MP3 for all compact and portable radios.**

<b>AWGN (°K)</b>	None	30,000	300,000
60 dB $\mu$	3.1	2.9	2.2
90 dB $\mu$	4.3	4.3	4.3
100 dB $\mu$	4.4	4.4	4.4

**Table 4 – Audio SNR change from MP1 to MP3 for all SCA subcarrier radios.**

<b>AWGN (°K)</b>	None	30,000	300,000
60 dB $\mu$	0.0	0.0	0.1
90 dB $\mu$	0.2	0.2	0.2
100 dB $\mu$	0.1	0.1	0.1

It is apparent that the automobile radios exhibited almost no change between MP1 and MP3 digital modes and any measured signal strength. The component stereo receiver and tuners showed a negligible 0.3 dB increase at 60 dB $\mu$ , rising to 1.3 dB at 100 dB $\mu$ . At the lowest signal strength, the white Gaussian noise had the most masking effect, eliminating any difference between MP1 and MP3.

The compact (table or shelf) radios and portables fared worst of the stereo receiver group, exhibiting an average of 3.1 dB increase in noise from MP1 to MP3, which was only slightly masked by the additive white Gaussian noise. Increases in noise are evident at higher signal strengths, as well. The cause of higher sensitivity by this group is uncertain, but since this group includes the lowest cost radios, it is possible that they have less effective IF (intermediate frequency) filters that admit more IBOC signal and have less AM noise rejection in the FM detector. The poorest performers were the two pocket portable units, listed first in the raw data.

An unexpected outcome was the performance of SCA subcarrier radios, which showed almost no change from MP1 to MP3. There was minimal change with increased signal strength, as well. Unlike the compact radios and portables, however, these radios were designed for the receiving low-injection FM subcarriers under a wide range of signal conditions. All of the units employ MOSFET or JFET RF amplifiers with wider dynamic range and greater pre-selection ahead of the mixer stage, and carefully designed IF filters and detectors. This appears to pay off in noise rejection, and serves as a guide in designing future receivers of all types for IBOC-to-Host FM compatibility.

Test results indicate that automotive, home stereo component and SCA receivers exhibit little or no susceptibility to analog Host interference from IBOC Extended Hybrid carriers. Shelf-type and portable receivers exhibit some increase, on the order of 3dB, which may be due to lower-cost tuner designs. This last category of systems may arguably utilize poorer speakers and audio amplifier circuits than component stereo and automotive systems, thereby audibly masking some of the noise increase noted.

## Appendix 1 - Receiver Measurement Data

### Table 5 – Automobile

Receiver			FM Stereo w/IBOC MP1			FM Stereo w/IBOC MP3		
Model	Type	RF Input Equiv. Field (dBuV)	No Addl Noise	w/30K	w/300K	No Addl Noise	w/30K	w/300K
<b>Kenwood HR-100</b> stereo Left out direct preamp output no 19kHz notch filter	Aftermarket Car Radio	60	-65.0	-62.8	-56.2	-65.0	-62.8	-56.2
		90	-66.1	-66.1	-66.0	-66.1	-66.0	-66.1
		100	-66.5	-66.1	-66.1	-66.2	-66.2	-66.2
<b>Pioneer DEH-1600</b> direct preamp output EQ off	Aftermarket Car Radio	60	-65.9	-61.5	-53.4	-65.5	-61.5	-53.4
		90	-66.1	-66.0	-66.0	-66.2	-66.0	-66.1
		100	-66.2	-66.1	-66.1	-66.1	-66.1	-66.1
<b>Honda 39110-S01-A010-M1</b> loudspeaker output 15 kHz LPF bass & treble flat	OEM Car Radio	60	-64.9	-62.4	-55.5	-64.9	-62.5	-55.5
		90	-65.2	-65.2	-65.2	-65.1	-65.1	-65.1
		100	-65.1	-65.1	-65.1	-65.1	-65.1	-65.1

**Table 6 - Component Receivers & Tuners**

Receiver		FM Stereo w/IBOC MP1 SNR				FM Stereo w/IBOC MP3 SNR		
Model	Type	RF Input Equiv. Field (dBuV)	No Addl Noise	w/30K	w/300K	No Addl Noise	w/30K	w/300K
<b>Sony STR-DE197</b> direct preamp output	Component	60	-66.4	-62.4	-55.0	-65.8	-62.6	-54.9
		90	-57.9	-57.9	-57.9	-56.4	-56.4	-56.4
		100	-48.0	-48.0	-48.0	-46.3	-46.4	-46.3
<b>Denon TU-380RD</b> direct preamp output	Component	60	-71.9	-71.6	-70.9	-71.7	-71.7	-70.8
		90	-71.3	-71.3	-71.3	-71.2	-71.2	-71.2
		100	-66.3	-66.3	-66.3	-66.1	-66.1	-66.1
<b>Denon TU-680NAB</b> Narrowband IF Mode " " Wideband IF Mode " "	Component	60	-69.8	-64.9	-56.4	-69.6	-65.0	-56.5
		90	-70.5	-70.5	-70.5	-69.7	-69.7	-69.7
		100	-64.4	-64.4	-64.4	-62.8	-62.8	-62.8
		60	-69.2	-64.4	-55.9	-69.1	-64.3	-55.9
		90	-69.9	-69.9	-69.9	-69.1	-69.1	-69.1
		100	-63.9	-63.9	-63.9	-62.2	-62.2	-62.2

**Table 7 – Compact & Portable Radios**

Receiver			FM Stereo w/IBOC MP1 SNR			FM Stereo w/IBOC MP3 SNR		
Model	Type	RF Input Equiv. Field (dBuV)	No Addl Noise	w/30K	w/300K	No Addl Noise	w/30K	w/300K
<b>Aiwa XP-R600</b> Headphone Output 15 kHz LPF (RF capacitively coupled to headphone cord)	Portable CD Player	60	-47.7	-47.5	-46.7	-43.3	-43.4	-43.0
		90	-50.3	-50.3	-50.3	-43.9	-43.9	-43.9
		100	-51.4	-51.4	-51.4	-43.6	-43.6	-43.6
<b>Sony WM-FX290</b> Headphone Output 15 kHz LPF (RF capacitively coupled to headphone cord)	Portable Walkman	60	-43.2	-43.2	-43.1	-41.7	-41.7	-41.7
		90	-48.3	-48.3	-48.3	-44.4	-44.4	-44.4
		100	-48.4	-48.4	-48.4	-44.5	-44.5	-44.5
<b>Sony ICF-SW7600G</b> Headphone Output 15 kHz LPF RF antenna input jack	Portable Radio	60	-56.6	-56.1	-53.1	-50.3	-50.3	-49.2
		90	-56.3	-56.3	-56.3	-50.5	-50.5	-50.5
		100	-55.1	-55.1	-55.1	-49.8	-49.8	-49.8
<b>RCA RCD147</b> Headphone Output 15 kHz LPF RF connected directly to telescopic antenna bass boost off, EQ off	Boom box	60	-43.5	-43.3	-41.3	-40.5	-40.5	-39.3
		90	-42.6	-42.6	-42.6	-38.4	-38.4	-38.4
		100	-42.1	-42.1	-42.1	-38.0	-38.0	-38.0
<b>Panasonic SC-PM19</b> Headphone Output 15 kHz LPF RF antenna input jack	Shelf System	60	-66.1	-66.1	-66.1	-66.0	-66.0	-66.0
		90	-63.0	-63.0	-62.9	-61.7	-61.7	-61.7
		100	-47.4	-47.4	-47.4	-46.4	-46.4	-46.4

**Table 8 – FM SCA Subcarrier Receivers**

Receiver			FM Stereo w/IBOC MP1 SNR			FM Stereo w/IBOC MP3 SNR		
Model	Type	RF Input Equiv. Field (dBuV)	No Addl Noise	w/30K	w/300K	No Addl Noise	w/30K	w/300K
<b>McMartin SCA TR-E5</b> direct preamp output 5kHz LPF & 120Hz HPF	SCA	60	-46.3	-46.2	-44.3	-46.4	-46.1	-44.0
		90	-51.0	-51.0	-51.0	-50.4	-50.4	-50.4
		100	-50.9	-50.9	-50.9	-50.6	-50.6	-50.6
<b>Compol SCA-8A</b> direct preamp output 5kHz LPF & 120Hz HPF	SCA	60	-45.1	-41.1	-33.2	-45.1	-41.2	-33.2
		90	-45.8	-45.8	-45.8	-45.7	-45.7	-45.7
		100	-38.6	-38.6	-38.6	-38.5	-38.5	-38.5
<b>Norver NU-1C</b> loudspeaker output 5kHz LPF & 120Hz HPF	SCA	60	-42.9	-42.8	-42.4	-42.9	-42.8	-42.3
		90	-43.0	-43.0	-43.0	-43.0	-43.0	-43.0
		100	-43.0	-43.0	-43.0	-43.0	-43.0	-43.0